



PIPER
CHEROKEE
OWNER'S HANDBOOK



753-683

CHEROKEE C

PA-28- 150-160-180

Owner's Handbook



**Piper Aircraft Corporation, Vero Beach, Florida
U.S. A.**

NOTICE

THIS HANDBOOK IS NOT DESIGNED, NOR CAN ANY HANDBOOK SERVE, AS A SUBSTITUTE FOR ADEQUATE AND COMPETENT FLIGHT INSTRUCTION, OR KNOWLEDGE OF THE CURRENT AIRWORTHINESS DIRECTIVES, THE APPLICABLE FEDERAL AIR REGULATIONS, AND ADVISORY CIRCULARS. IT IS NOT INTENDED TO BE A GUIDE OF BASIC FLIGHT INSTRUCTION, NOR A TRAINING MANUAL.

THE HANDBOOK IS DESIGNED:

1. TO HELP YOU OPERATE YOUR CHEROKEE WITH SAFETY AND CONFIDENCE.
2. TO MORE FULLY ACQUAINT YOU WITH THE BASIC PERFORMANCE AND HANDLING CHARACTERISTICS OF THE AIRPLANE.
3. TO MORE FULLY EXPLAIN YOUR CHEROKEE'S OPERATION THAN IS PERMISSIBLE TO SET FORTH IN THE AIRPLANE FLIGHT MANUAL.

IF THERE IS ANY INCONSISTENCY BETWEEN THIS HANDBOOK AND THE AIRPLANE FLIGHT MANUAL APPROVED BY THE F.A.A., THE AIRPLANE FLIGHT MANUAL SHALL GOVERN.

Revised text and illustrations shall be indicated by a black vertical line in the margin opposite the change. A line opposite the page number will indicate that material was relocated.

Additional copies of this manual, Part No. 753 683, may be obtained from your Piper Dealer.

Published by
PUBLICATIONS DEPARTMENT
Piper Aircraft Corporation
753 683
Issued: August 1964
Revised: February 2, 1979

SECTION I

SPECIFICATION FEATURES

Power Plant	1
Performance	1
Weights	2
Fuel and Oil	3
Baggage	3
Dimensions	3
Landing Gear	3

SPECIFICATION FEATURES:

<u>POWER PLANT</u>	<u>PA-28-150</u>	<u>PA-28-160</u>	<u>PA-28-180</u>
Engine - Lycoming	O-320-E2A	O-320-D2A	O-360-A3A
Rated Horsepower	150	160	180
Rated Speed	2700	2700	2700
Bore, inches	5.125	5.125	5.125
Stroke, inches	3.875	3.875	4.375
Displacement (cubic inches)	319.8	319.8	361.0
Compression Ratio	7:1	8.5:1	8.5:1
Dry Weight, pounds	272	278	285
Fuel Consumption (75% power, gph)	9	9	10
Oil Sump Capacity (qts)	8	8	8
Fuel Aviation Grade (Minimum Octane)	80	91/96	91/96
(Specified Octane)	80	91/96	91/96
(Alternate Fuels)	See Fuel Requirements, page 30		
Propeller (Sensenich)	M74DMS	M74DMS	M76EMMS

PERFORMANCE

Take-off Run, ft. **	780	740	720
Best Rate of Climb Speed (MPH)	85	85	85
Rate of Climb (ft. per min.)	690	730	750
Service Ceiling (ft.)	14,900	15,800	16,400
Absolute Ceiling	17,400	18,400	19,000
Top Speed (MPH)	141 (144*)	143 (146*)	152
Cruising Speed (75% power, sea level MPH)	123 (124*)	125 (128*)	134
Optimum Cruising Speed (75% power, 7000 ft., MPH)	132 (135*)	134 (137*)	143

* Wheel fenders optional equipment on PA-28-150 and 160

** Max. effort, 25° flap

SPECIFICATION FEATURES: (cont.)PERFORMANCE

Fuel Consumption (gal. per hr. 75%	9	9	10
Cruising Range (75% power, sea level, std. fuel)	4 hrs. (5.5#) 500 mi. (690#)	4 hrs. (5.5#) 510 mi. (705#)	5 hrs. 680 mi.
Cruising Range (75% power, 7000 ft., std. fuel)	4 hrs. (5.5#) 525 mi. (725#)	4 hrs. (5.5#) 535 mi. (735#)	5 hrs. 725 mi.
Optimum Cruising Range (55% power, 10,000 ft. std. fuel 7.2 gph)	5 hrs. (7.0#) 580 mi. (800#)	5 hrs. (7.0#) 590 mi. (815#)	6.8 hrs. 845 mi.
Stalling Speed (flaps down, MPH)	54	55	57
Landing Roll (flaps down, ft.)	535	550	600

#50 gal. reserve fuel

Performance figures are for airplanes equipped for cross-country transportation flown at gross weight under standard conditions at sea level, or stated altitude. Any deviation of equipment may result in changes in performance.

<u>WEIGHTS</u>	<u>PA-28-150</u>	<u>PA-28-160</u>	<u>PA-28-180</u>
Gross Weight (lbs.)	2150	2200	2400
Empty Weight (Standard) (lbs.)	1210	1215	1230
USEFUL LOAD (Standard) (lbs.)	940	985	1170
Empty Weight (AutoFlight) (lbs.)	1250	1255	1270

SPECIFICATION FEATURES (cont.)

<u>WEIGHTS</u>	<u>PA-28-150</u>	<u>PA-28-160</u>	<u>PA-28-180</u>
<u>USEFUL LOAD</u>			
(AutoFlight) (lbs.)	900	945	1130
<u>FUEL AND OIL</u>			
Fuel Capacity (Standard) (gal)	36	36	50
Fuel Capacity (with reserve) (gal)	50	50	
Oil Capacity (qts)	8	8	8
<u>BAGGAGE</u>			
Maximum Baggage (lbs)	200	200	200
Baggage Space (cubic ft)	17	17	17
Baggage Door Size (in)	20x22	20x22	20x22
<u>DIMENSIONS</u>			
Wing Span (ft)	30	30	30
Wing Area (sq. ft)	160	160	160
Wing Loading (lbs. per sq. ft)	13.4	13.8	15.0
Length (ft)	23.5	23.5	23.5
Height (ft)	7.3	7.3	7.3
Power Loading (lbs. per HP)	14.3	13.8	13.3
<u>LANDING GEAR</u>			
Wheel Base (ft)	6.2	6.2	6.2
Wheel Tread (ft)	10	10	10
Tire Pressure	Nose 24	24	24
	Main 24	24	24

SECTION II

DESIGN INFORMATION

Engine and Propeller	5
Structures	5
Landing Gear	6
Control Systems	7
Fuel System	7
Electrical System	8
Heating and Ventilating System	9
Cabin Features	9

SECTION II

DESIGN INFORMATION

ENGINE AND PROPELLER

The Cherokee is powered by a Lycoming engine of either 150, 160 or 180 H. P. (Refer to power plant specifications on page 1) Each engine is furnished with a starter, 35 ampere 12 volt alternator, voltage regulator, shielded ignition, vacuum pump drive, fuel pump and a dry, automotive type carburetor air filter.

The exhaust system is of the cross-over type to reduce back pressure and improve performance. It is made entirely from stainless steel and is equipped with dual mufflers. A heater shroud around the mufflers is provided to supply heat for both the cabin and carburetor de-icing.

The Sensenich fixed-pitch propeller is made from a one-piece alloy forging. Refer to the Power Plant Specifications on page 1 for the model of propeller used with each engine.

STRUCTURES

All structures are of aluminum alloy construction and are designed to ultimate load factors well in excess of normal requirements. All exterior surfaces are primed with etching primer and painted with acrylic enamel.

The wings are attached to each side of the fuselage by inserting the butt ends of the respective main spars into a spar box carry through which is an integral part of the fuselage structure, providing in effect a continuous main spar with splices at each side of the fuselage. There are also fore and aft attachments at the rear spar and at an auxiliary front spar.

The wing airfoil section is a laminar flow type, NACA 65₂-415 with the maximum thickness about 40% aft of the leading edge. This permits the main spar carry through structure to be located under the rear seat providing unobstructed cabin

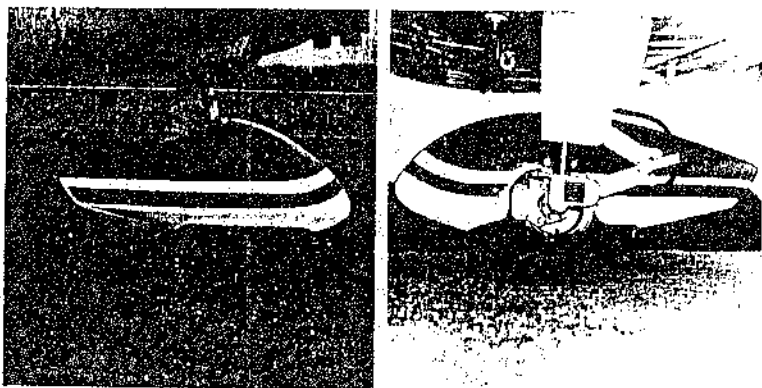

floor space ahead of the rear seat.

LANDING GEAR

The three landing gears use a Cleveland 600 x 6 wheel, the main wheels being provided with Cleveland single disc hydraulic brake assemblies, No. 30-55. All wheels use 600 x 6 four ply tires with tubes.

The nose gear is steerable through a 30 degree arc by use of the rudder pedals. A spring device is incorporated in the rudder pedal torque tube assembly to aid in rudder centering and to provide rudder trim. The nose gear steering mechanism also incorporates a hydraulic shimmy dampener.

The oleo struts are of the air-oil type, with normal extension being 3.25 inches for the nose gear and 4.50 inches for the main gear under normal static load (empty weight of airplane plus full fuel and oil).

The standard brake system for the Cherokee consists of a hand lever and master cylinder which is located below and behind the left center of the instrument sub-panel. The brake fluid reservoir is installed on the top left front face of the firewall. The parking brake is incorporated in the master cylinder and is actuated by pulling back on the brake lever, depressing the knob attached to the handle and releasing the brake lever. To release the parking brake, pull back on the lever to disengage the catch mechanism and allow the handle to swing forward.

Optional toe brakes are available to supplement the standard hand lever and parking brake system.

CONTROL SYSTEMS

Dual controls are provided as standard equipment, with a cable system used between the controls and the surfaces. The horizontal tail is of the all movable slab type, with an anti-servo tab which also acts as a longitudinal trim tab, actuated by a control on the cabin ceiling. The stabilator provides extra stability and controllability with less size, drag, and weight than conventional tail surfaces. The ailerons are provided with a differential action which tends to eliminate adverse yaw in turning maneuvers, and also reduces the amount of coordination required in normal turns.

The flaps are manually operated, balanced for light operating forces and spring loaded to return to the up position. A past-center lock incorporated in the actuating linkage holds the flap when it is in the up position so that it may be used as a step on the right side. The flap will not support a step load except when in the full up position, so it must be completely retracted when used as a step. The flaps have three extended positions, 10, 25 and 40 degrees.

FUEL SYSTEM

Fuel is stored in two twenty-five gallon tanks which are secured to the leading edge structure of each wing by screws and nut plates. This allows easy removal for service or inspection.

The standard quantity of fuel is 36 gallons for the Cherokee 150 and 160 and 50 gallons for the Cherokee 180. To obtain the standard quantity of 36 gallons of fuel on the 150 and 160 fill the tanks only to the bottom of the filler neck indicator, which extends some distance into the tanks. To fill to the standard plus

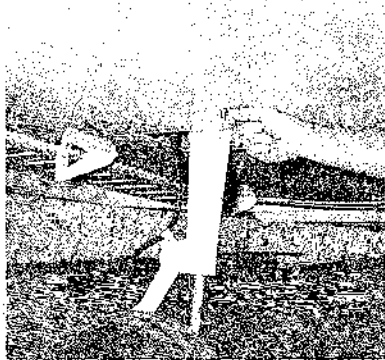

reserve quantity of 50 gallons the tanks are filled completely to the top. This system allows the fuel quantity to be varied conveniently according to the payload.

An auxiliary electric fuel pump is provided for use in case of failure of the engine driven pump. The electric pump should be on for all take-offs and landings.

The fuel strainer, which is equipped with a quick drain, is located on the front lower left corner of the firewall. This strainer should be drained regularly to check for water or sediment accumulation. To drain the lines from the tanks, the tank selector valve must be switched to each tank in turn, with the electric pump on, and the gascolator drain valve opened. Each tank has an individual quick drain located at the bottom, inboard, rear corner.

Fuel quantity and pressure are indicated on gauges located in the engine gauge cluster on the right side of the instrument panel.

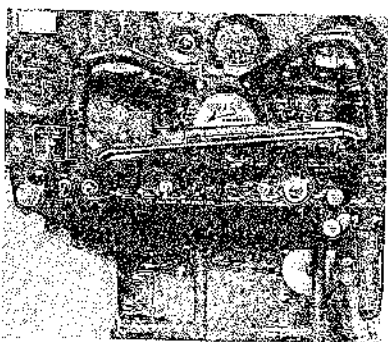

ELECTRICAL SYSTEM

The electrical system includes a 12 volt alternator, battery, voltage regulator and master switch relay. The battery, regulator and relay are mounted in the battery compartment immediately aft of the baggage compartment. Access for service or inspection is conveniently obtained through a removable

panel at lower right corner of the compartment.

Electrical switches, fuses and fuse spares are located on the lower left center of the instrument panel, and the left side of the instrument sub-panel.

Standard electrical accessories include: Starter, Electric Fuel pump, Fuel Gauge, Stall Warning Indicator, Cigar Lighter and Ammeter.

Navigation Lights, Anti-Collision Light, Landing Light, Instrument Lighting and the Cabin Dome Light are offered as optional accessories.

Circuit provisions are made to handle optional communications and navigational equipment.

Installed on the Cherokees is the F.T.P. (full time power) electrical system.

Derived from the system are many advantages both in operation and maintenance. The main advantage is, of course, full electrical power output regardless of engine R.P.M. This is a great improvement for radio and electrical equipment operation. Also because of the availability of generator output at all times, the battery will be charging for a greater percentage of use, which will greatly improve cold-morning starting.

Unlike previous generator systems, the ammeter does not indicate battery discharge; rather it displays in amperes the load placed on the alternator. With all electrical equipment off (except the master switch) the ammeter will be indicating the amount of charging current demanded by the battery. As each item of electrical equipment is turned on, the current will increase to a total appearing on the ammeter. This total includes the battery. The maximum continuous load for night flight, with radios on, is about 30 amperes. This 30 ampere value, plus approximately two amperes for a fully charged battery, will appear continuously under these flight conditions. The amount of current shown on the ammeter will tell immediately whether the alternator system is operating normally, as the amount of current shown should equal the total amount of amperes being drawn by the equipment which is operating.

If no output is indicated on the ammeter during flight, re-

duce the electrical load by turning off all unnecessary electrical equipment. Check both 5 ampere field breaker and 60 ampere output breaker and reset if open. If neither circuit breaker is open, turn off the master switch for 30 seconds to reset the overvoltage relay. If ammeter continues to indicate no output, maintain minimum electrical load and terminate flight as soon as practical.

HEATING AND VENTILATING SYSTEM

Heat for the cabin interior and the defroster system is provided by a heater muff attached to the exhaust system. The amount of heat desired can be regulated with the controls located on the lower right side of the instrument panel.

Fresh air inlets are located in the leading edge of the wing at the intersection of the tapered and straight sections. A large adjustable outlet is located on the side of the cabin near the floor at each seat location

CABIN FEATURES

The instrument panel of the Cherokee is designed to accommodate the customary advanced flight instruments and all the normally required power plant instruments. The Artificial Horizon, Directional Gyro and some Turn and Bank instruments are vacuum operated through use of a vacuum pump installed on the engine. Later C Model Cherokees are equipped with electric Turn and Bank instruments. A natural separation of the flight group and the power group is provided by placing the communications and radio navigational equipment in the center of the panel.

The front seats are adjustable fore and aft for pilot comfort and ease of entry and exit.

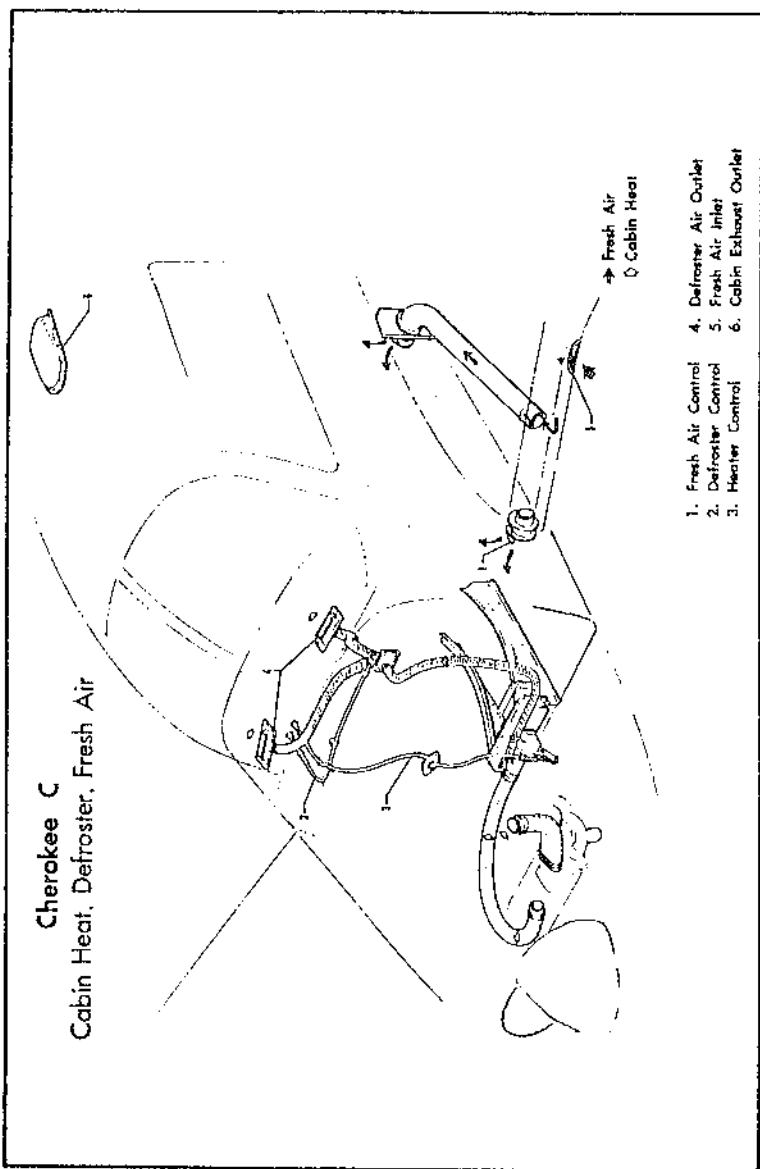

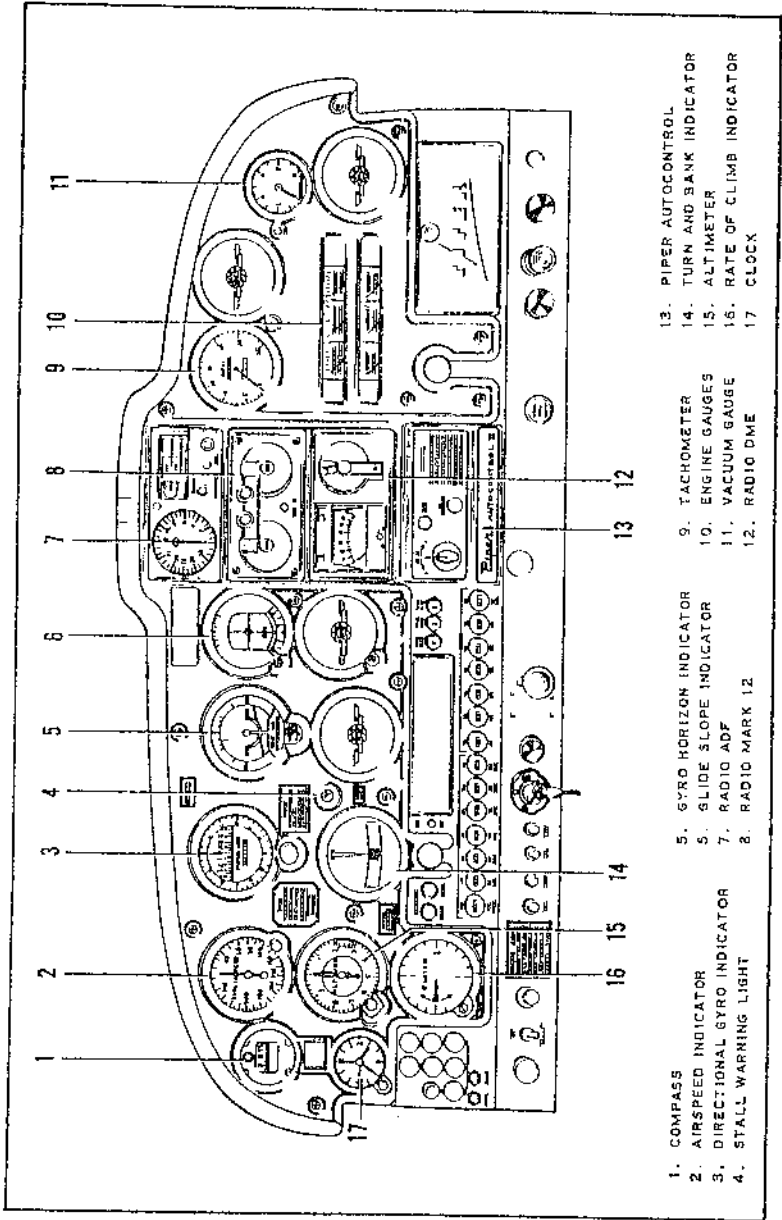

SECTION III
OPERATING INSTRUCTIONS

Preflight	13
Starting	14
Warm-up	15
Ground Check	16
Take-off	16
Climb	17
Stalls	17
Cruising	17
Approach and Landing	18
Ground Handling and Mooring	19
Weight and Balance	20

SECTION III

OPERATING INSTRUCTIONS

PREFLIGHT

Inspect the airplane as follows:

1. a. Master switch "ON".
b. Check fuel quantity indicators (two tanks).
c. Master switch and ignition "OFF".
2. a. Check for external damage or operational interference to the control surfaces, wings or fuselage.
b. Check that there is no snow, ice or frost on the wings or control surfaces.
3. a. Check fuel supply visually and secure caps.
b. Drain fuel tank sumps.
c. Check to insure that the fuel system vents are open.

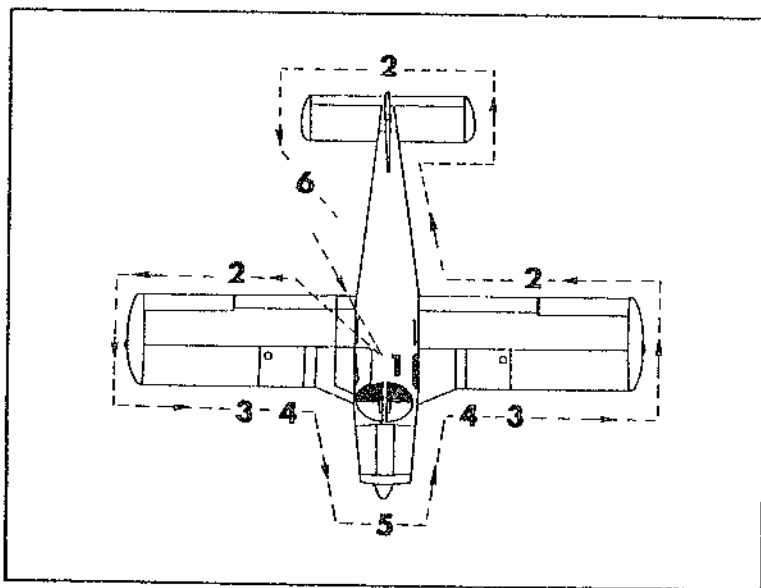

4. a. The landing gear shock struts are properly inflated, (Refer to Section V)
 - b. The tires are satisfactorily inflated and not excessively worn.
5. a. The cowling and inspection covers are secured,
 - b. The windshield is clean and free of defects.
 - c. The propeller is free of detrimental nicks.
 - d. There are no obvious fuel or oil leaks.
 - e. The engine oil is at the proper level.
 - f. Drain the fuel strainer with the fuel selector valve in left or right tank position.
6. a. The tow-bar and control locks are detached and properly stowed.
7. a. Upon entering the airplane, ascertain that all controls operate properly.
 - b. Close and secure the cabin door.
 - c. Check that required papers are in order and in the airplane.
 - d. Fasten safety belts and shoulder harness. Check inertia reel.

STARTING

After completion of preflight inspection:

1. Lock the wheel brakes.
2. Set the carburetor heat control in the full "COLD" position.
3. Select the desired tank with the fuel valve.
4. Move the mixture to the full "RICH" position.
5. Open the throttle 1/8 to 1/4 inch.
6. Turn the electric fuel pump "ON".

In cold weather (below 40 degrees F.) prime the engine with one to three full strokes of the priming pump. If extremely cold, starting will be aided by pulling the propeller through by hand (switch "OFF") four to five revolutions. If the temperature is above 40 degrees the engine may be primed by three or four short quick strokes of the throttle.

After priming, turn the electric master switch on, engage the starter and allow the engine to turn approximately one full revolution, then turn the ignition switch to the "Left" magneto

position.

When the engine is firing evenly, turn the magneto switch to the "Both" position and advance the throttle to 800 RPM. Check the oil pressure gauge for a pressure indication. If oil pressure is not indicated within thirty seconds, stop the engine and determine the trouble.

If the engine fails to start at the first attempt, another attempt should be made without priming. If this fails, it is possible that the engine is overprimed. Turn the magneto switch off, open the throttle slowly, and rotate the engine approximately ten revolutions with the starter. Reprime the engine with one half the amount used in the initial attempt, turn the magneto switch to "Left", and repeat the starting procedure. If the engine again fails to start, refer to the Lycoming Operating Handbook, Section VII, Engine Troubles.

WARM-UP

As soon as the engine starts, the oil pressure should be checked. If no pressure is indicated within thirty seconds, stop the engine and determine the trouble. In cold weather it will take a few seconds longer to get an oil pressure indication. Warm-up the engine at 800 to 1200 RPM.

Take-off may be made as soon as ground check is completed, providing that the throttle may be opened fully without back firing or skipping, and without reduction in engine oil pressure.

GROUND CHECK

With the engine running at 2000 RPM, switch from both magnetos to only one and note the RPM loss; switch to the other magneto and again note the RPM loss. Drop off on either magneto should not exceed 125 RPM.

Check vacuum gauge. Indicator should read 5" Hg \pm .1" Hg at 2000 RPM.

Check both the oil temperature and pressure. The temperature may be low for some time if the engine is being run for the first time of the day, but as long as the pressure is within limits the engine is ready for take-off.

Carburetor heat should also be checked prior to take-off to be sure that the control is operating properly and to clear any ice which may have formed during taxiing. Avoid prolonged ground operation with carburetor heat ON as the air is unfiltered.

Mixture should be set full rich, except a minimum amount of leaning is permitted for smooth engine operation when taking off at high elevation.

TAKE-OFF

Just before take-off the following items should be checked:

1. Controls
2. Flaps "UP"
3. Tab set
4. Mixture "RICH"
5. Carburetor heat "OFF"
6. Fuel on proper tank
7. Electric fuel pump "ON"
8. Engine gauges normal
9. Door latched
10. Altimeter set
11. Safety belts/shoulder harness - fastened

The take-off technique is conventional for the Cherokee. The tab should be set slightly aft of neutral, with the exact setting determined by the loading of the aircraft. Allow the airplane to accelerate to 50 to 60 miles per hour, then ease back on the wheel enough to let the airplane fly itself off the ground. Premature raising of the nose, or raising it to an excessive angle will result in a delayed take-off. After take-off let the aircraft accelerate to the desired climb speed by lowering the nose slightly. To shorten take-off distance, flaps extended up to 25° may be used.

CLIMB

The best rate of climb at gross weight will be obtained at 85 miles per hour. The best angle of climb may be obtained at 74 miles per hour. At lighter than gross weight these speeds are reduced somewhat. For climbing enroute a speed of 100 miles per hour is recommended. This will produce better forward speed and increased visibility over the nose during the climb.

STALLS

The gross weight stalling speed of the Cherokee with power off and full flaps is 54 MPH on the 150, 55 MPH on the 160 and 57 MPH on the Cherokee 180. This speed is increased 9 miles per hour with the flaps up. Stall speeds at lower weights will be correspondingly less.

CRUISING

The cruising speed of the Cherokee is determined by many factors including power setting, altitude, temperature, loading, and equipment installed on the airplane.

The normal cruising power is 75% of the rated horsepower of the engine. True airspeeds which may be obtained at various altitudes and power settings can be determined from the charts in "Section IV" of this handbook.

Use of the mixture control in cruising flight reduces fuel consumption significantly, especially at higher altitudes, and reduces lead deposits when the alternate fuels are used. The mixture should be leaned when 75% power or less is being used. If any doubt exists as to the amount of power being used, the mixture should be in the FULL RICH position for all operations. Always enrich the mixture before increasing power settings.

The continuous use of carburetor heat during cruising flight decreases engine efficiency. Unless icing conditions in the carburetor are severe, do not cruise with the heat on. Apply full carburetor heat slowly and only for a few seconds at intervals determined by icing severity.

In order to keep the airplane in best lateral trim during cruising flight the fuel should be used alternately from each tank. It is recommended that one tank should be used for one hour after take-off, then the other tank used for two hours, then return to the first tank, which will have approximately one and one half hour of fuel remaining if the tanks were full plus reserve at take-off. The second tank will contain approximately one half hour of fuel.

APPROACH AND LANDING

Landing check list:

- | | |
|------------------------|-------------------------|
| 1. Fuel on proper tank | 4. Flaps - set |
| 2. Mixture - rich | 5. Fasten belts/harness |
| 3. Elec. fuel pump on | |

The airplane should be trimmed to an approach speed of about 85 miles per hour, with flaps up. The flaps can be lowered at speeds up to 115 miles per hour, if desired, and the approach speed reduced 3 MPH for each additional notch of flaps. Carburetor heat should not be applied unless there is an indication of carburetor icing, since the use of carburetor heat causes a reduction in power which may be critical in case of a go-around. Full throttle operation with heat on is likely to cause detonation.

The amount of flap used during landings and the speed of the aircraft at contact with the runway should be varied according to the landing surface, and existing conditions both windwise and loadwise. It is generally good practice to contact the ground at the minimum possible safe speed consistent with existing conditions.

Normally the best technique for short and slow landings is to use full flap and enough power to maintain the desired air-speed and approach flight path. Mixture should be full rich, fuel on the fullest tank, carburetor heat off, and electric fuel pump on. Reduce the speed during the flareout and contact the ground close to the stalling speed (50 to 60 MPH). After ground contact hold the nose wheel off, as long as possible. As the airplane slows down, drop the nose and apply the brakes. There will be less chance of skidding the tires if the flaps are retracted before applying the brakes. Braking is most effective when back pressure is applied to the control wheel, putting most of the aircraft weight on the main wheels. In high wind conditions, particularly in strong cross winds, it may be desirable to approach the ground at higher than normal speeds, with partial or no flaps.

To stop the engine, after landing and when clear of the runway, pull the mixture control full out to idle cut-off. When using alternate fuels, the engine should be run up to 1200 R.P.M. for one minute prior to shutdown to clean out any unburned fuel. After the engine stops, turn the ignition and master switches off, and retract the flaps.

GROUND HANDLING AND MOORING

The Cherokee should be moved on the ground with the aid of the nose wheel tow bar provided with each plane and secured in the baggage compartment. Tie downs may be secured to rings provided under each wing, and to the tail skid. The aileron and stabilator controls should be secured by looping the safety belt through the control wheel, and pulling it tight. The rudder is held in position by its connections to the nose wheel steering, and normally does not have to be secured. The flaps are locked when in the full up position, and should be left retracted.

WEIGHT AND BALANCE

It is the responsibility of the owner and pilot to determine that the airplane remains within the allowable weight vs center of gravity envelope while in flight. For weight and balance data see the Airplane Flight Manual and Weight and Balance Form supplied with each airplane.

SECTION IV

PERFORMANCE CHARTS

Take-off Distance vs Density Altitude	21
Rate of Climb vs Density Altitude	22
True Airspeed and RPM vs Density Altitude, PA-28-150 -160	23
Range vs Density Altitude, PA-28-150 -160	24
True Airspeed and RPM vs Density Altitude, PA-28-180	25
Range vs Density Altitude, PA-28-180	26
Landing Distance vs Density Altitude	26a
Altitude Conversion Chart	26b

PIPER CHEROKEE C PA-28-150-160-180

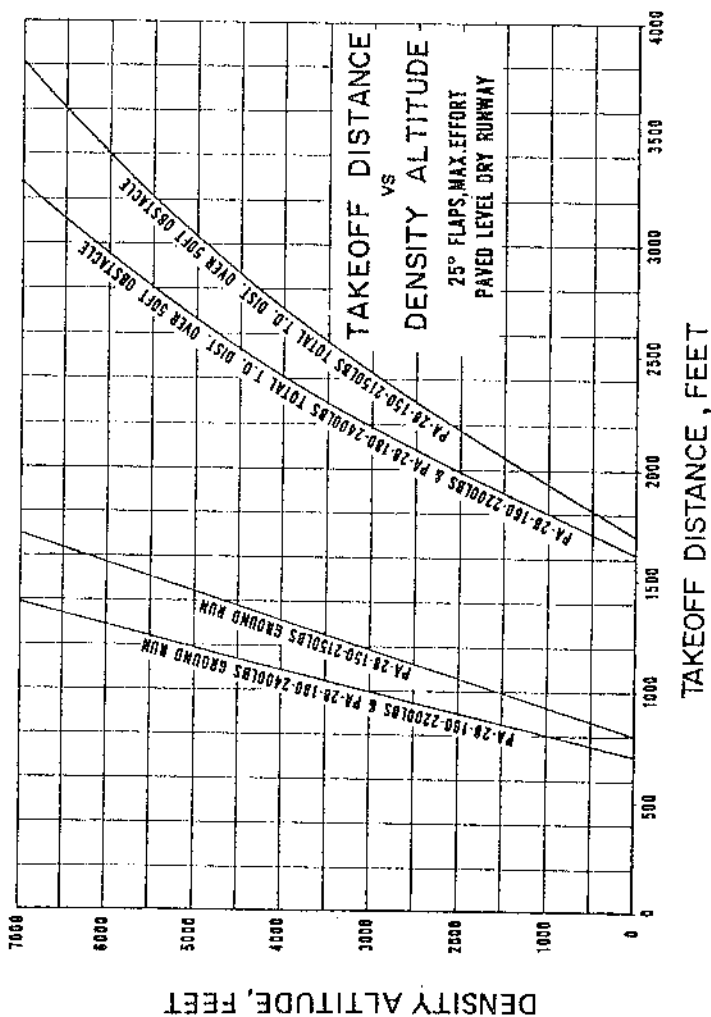

PIPER CHEROKEE C

PA-28-150-160-180

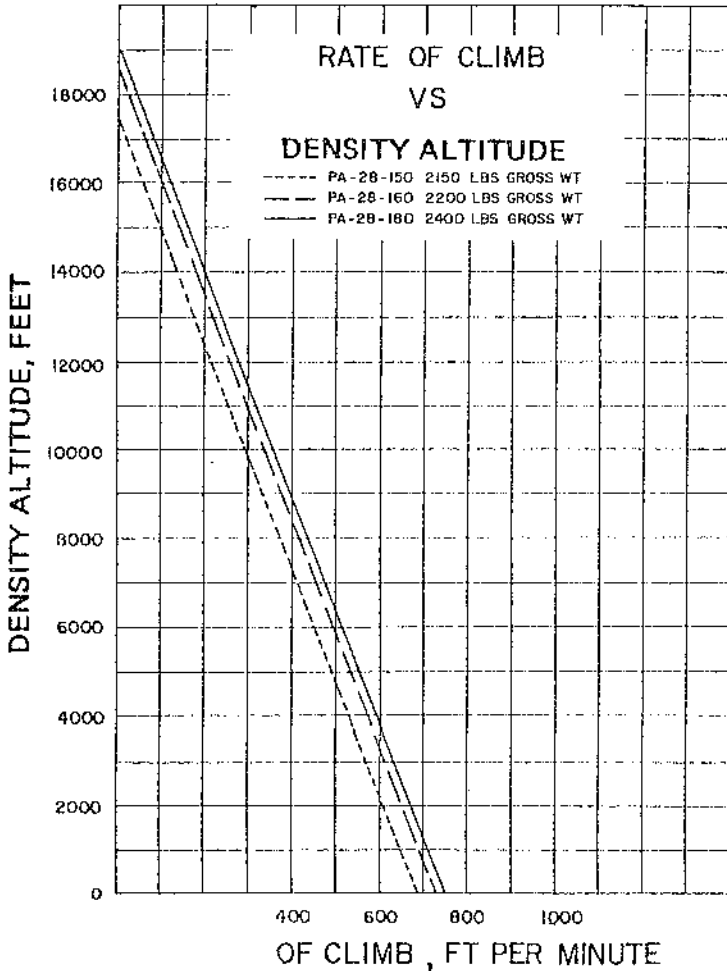

PIPER CHEROKEE C PA-28-150-160

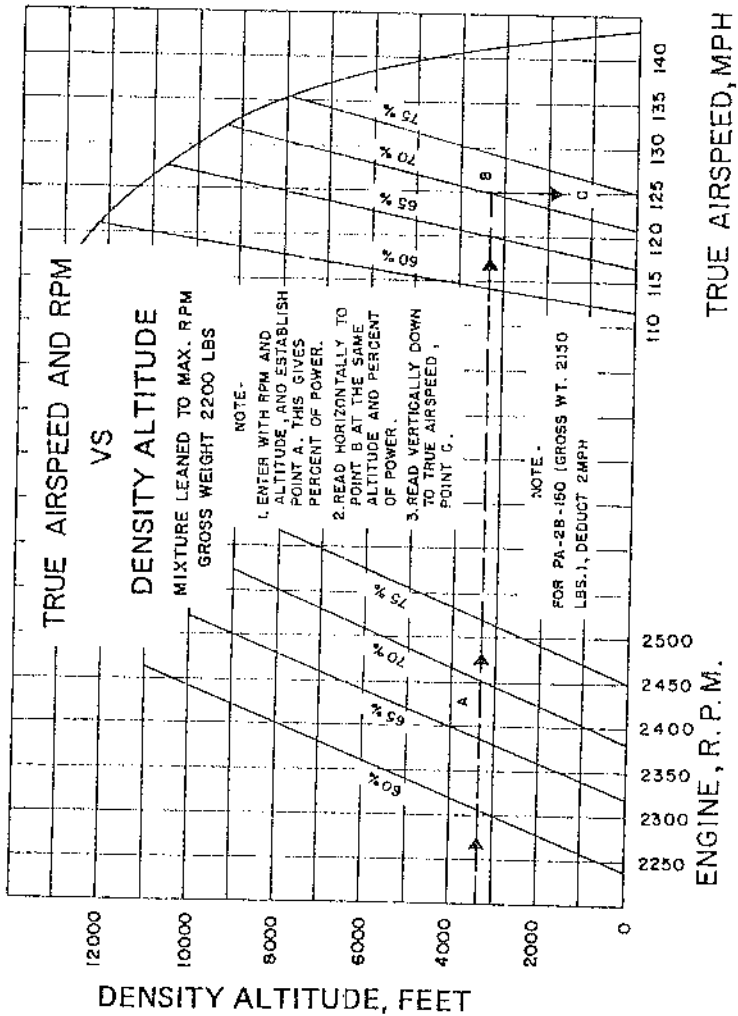

PIPER CHEROKEE C

PA-28-150 -160

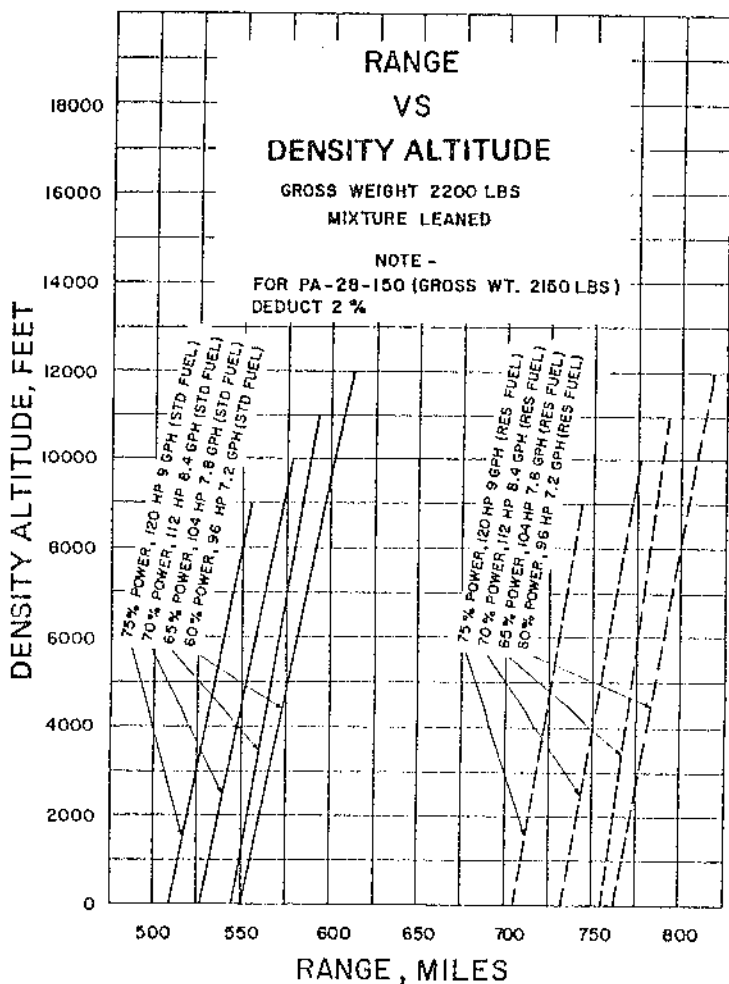

PIPER CHEROKEE C PA-28-180

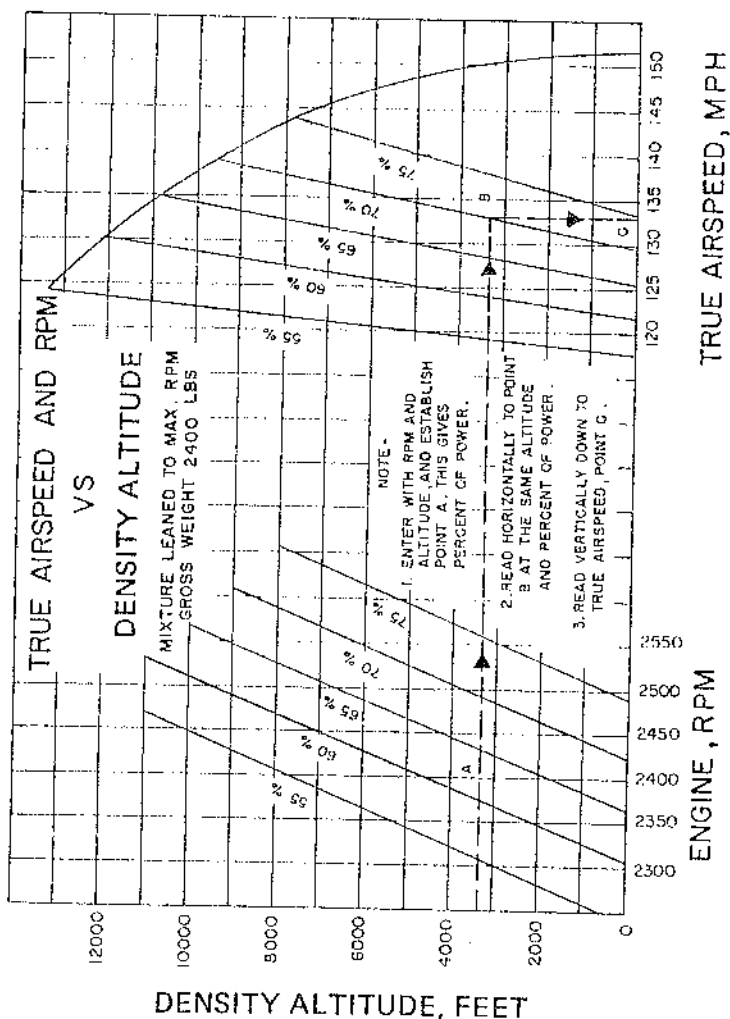

PIPER CHEROKEE C PA-28-180

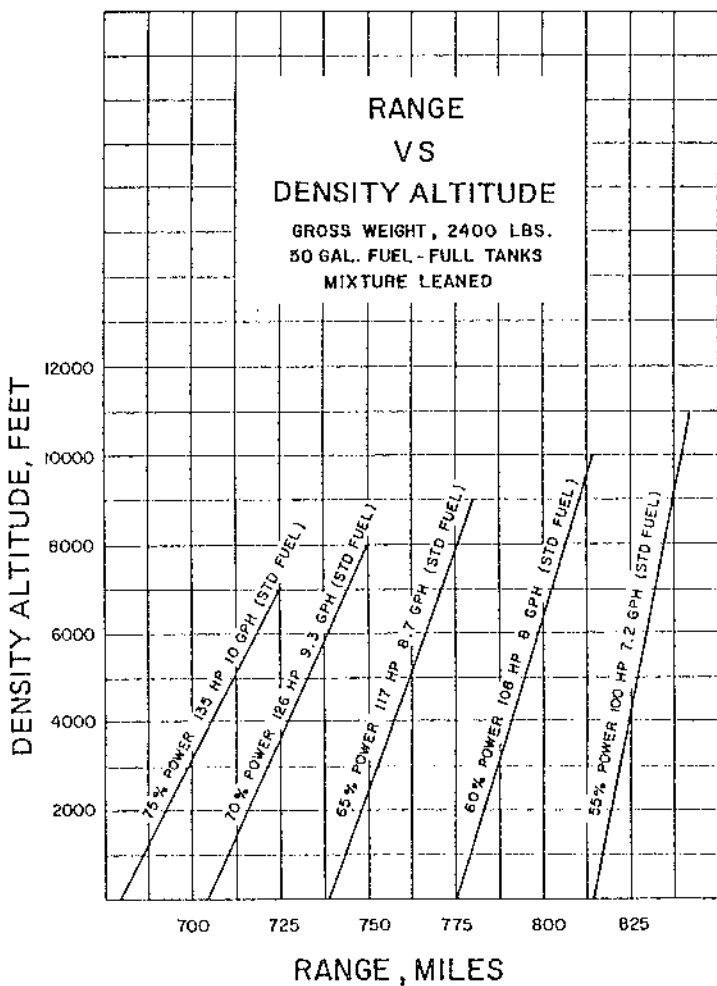

PIPER CHEROKEE C PA-28-150-160-180

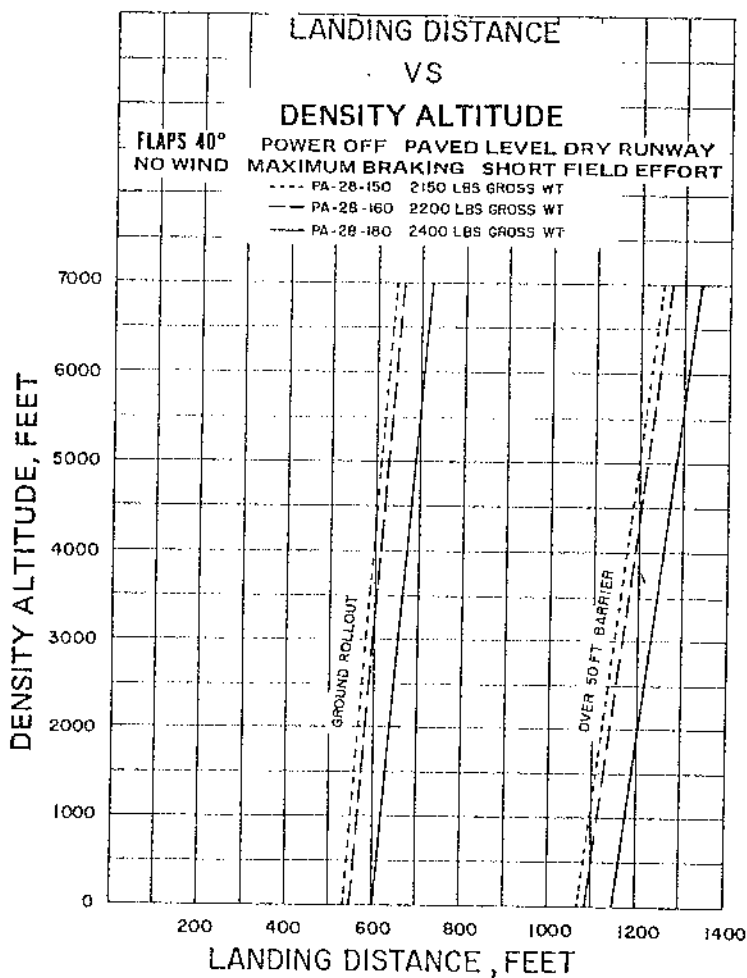

PIPER CHEROKEE C PA-28-150-160-180

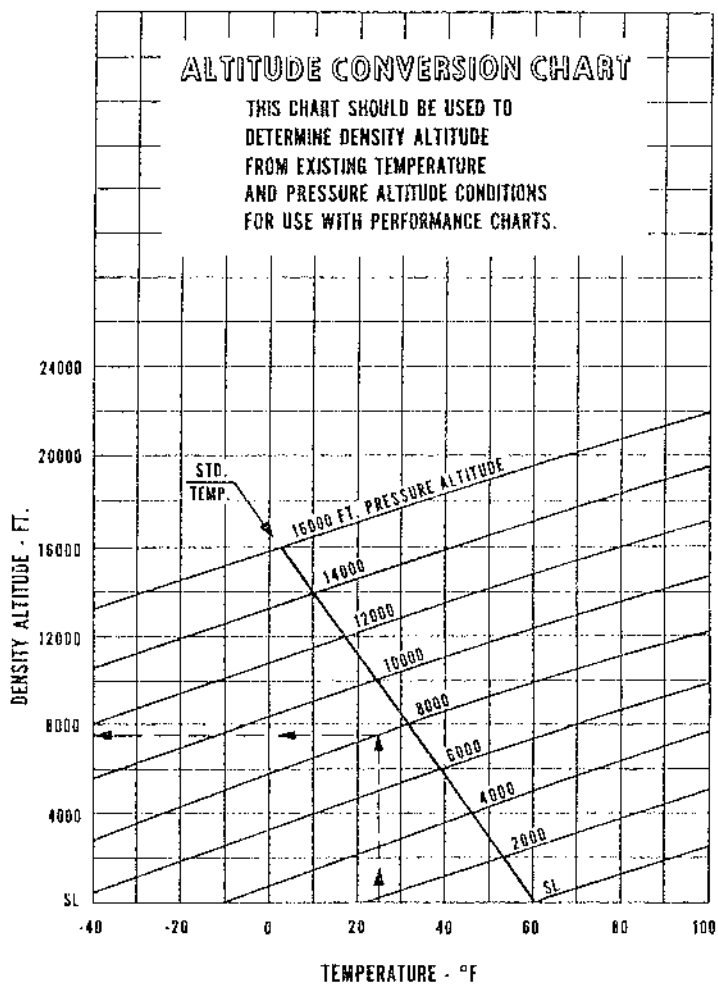

SECTION V
GENERAL MAINTENANCE

Tire Inflation	27
Battery Service	27
Brake Service	27
Landing Gear Service	28
Fuel Requirements.....	30
Oil Requirements	31
Care of Air Filter.....	32
Care of Windshield and Windows	32
Serial Number Plate	32
Leveling and Rigging	34

SECTION V

GENERAL MAINTENANCE

TIRE INFLATION

For maximum service from the tires on the Cherokee, keep the tires inflated to the proper pressure of 24 pounds for the main gear, and 24 pounds for the nose wheel. Interchange the tires on the main wheels if necessary to produce even wear. All wheels and tires are balanced before original installation, and the relationship of the tire, tube and wheel should be maintained if at all possible. Out of balance wheels can cause extreme vibration on take-off. In the installation of new components, it may be necessary to rebalance the wheel with the tires mounted.

BATTERY SERVICE

Access to the 12 volt battery is through the right rear baggage compartment panel. The stainless steel box has a plastic drain tube which is normally closed off with a clamp and which should be opened occasionally to drain off any accumulation of liquid. The battery should be checked for proper fluid level, but must not be filled above the baffle plates. A hydrometer check should be performed to determine the percent of charge present in the battery.

If the battery is discharged, charge it before take-off as three volts are needed to excite the alternator. Recharge starting at a 4 amp rate and finishing with a 2 amp rate. Quick charges are not recommended.

BRAKE SERVICE

The brake system is filled with MIL-H-5606 (petroleum base) hydraulic brake fluid. This should be checked at every 100 hour inspection and replenished when necessary by filling the brake reservoir on the firewall to the indicated level. If the system as a whole has to be refilled with fluid, this should

be done by filling with the fluid under pressure, from the brake end of the system. This will eliminate air from the system as it is being filled.

No adjustment of brake clearances is necessary on the Cherokee brakes. If after extended service the brake blocks become worn excessively, they are easily replaced with new segments.

LANDING GEAR SERVICE

Main wheels are easily removed by taking off the hub cap, axle nut, and the two bolts holding the brake segment in place, after which the wheel slips easily from the axle.

Tires are demounted from the wheels by first deflating the tire, then removing the three through bolts, and separating the wheel halves.

Landing gear oleo struts should be checked for proper strut exposures and fluid leaks. The required extensions for the strut when under normal static load (empty weight of airplane plus full fuel and oil) is 3.25 inches for the nose gear and 4.50 inches for the main gear. Should the strut exposure be below that required, it should be determined whether air or oil is required by first raising the airplane on jacks. Depress the valve core to allow air to escape from the strut housing chamber. Remove the filler plug and slowly raise the strut to full compression. If the strut has sufficient fluid it will be visible up to the bottom of the filler plug hole and will then only require proper inflation.

Should fluid be below the bottom of the filler plug hole, oil should be added. Replace the plug with valve core removed, attach a clear plastic hose to the valve stem of the filler plug and submerge the other end in a container of hydraulic fluid (MIL-H-5606). Fully compress and extend the strut several times thus drawing fluid from the container and expelling air from the strut chamber. To allow fluid to enter the bottom chamber of the main gear strut housing, the torque link assembly must be disconnected to let the strut be extended a minimum of 10 inches. (The nose gear torque links need not be disconnected.) Do not allow the strut to extend more than 12 inches.

Cherokee C Fuel System
 PA-28-150, PA-28-160, PA-28-180

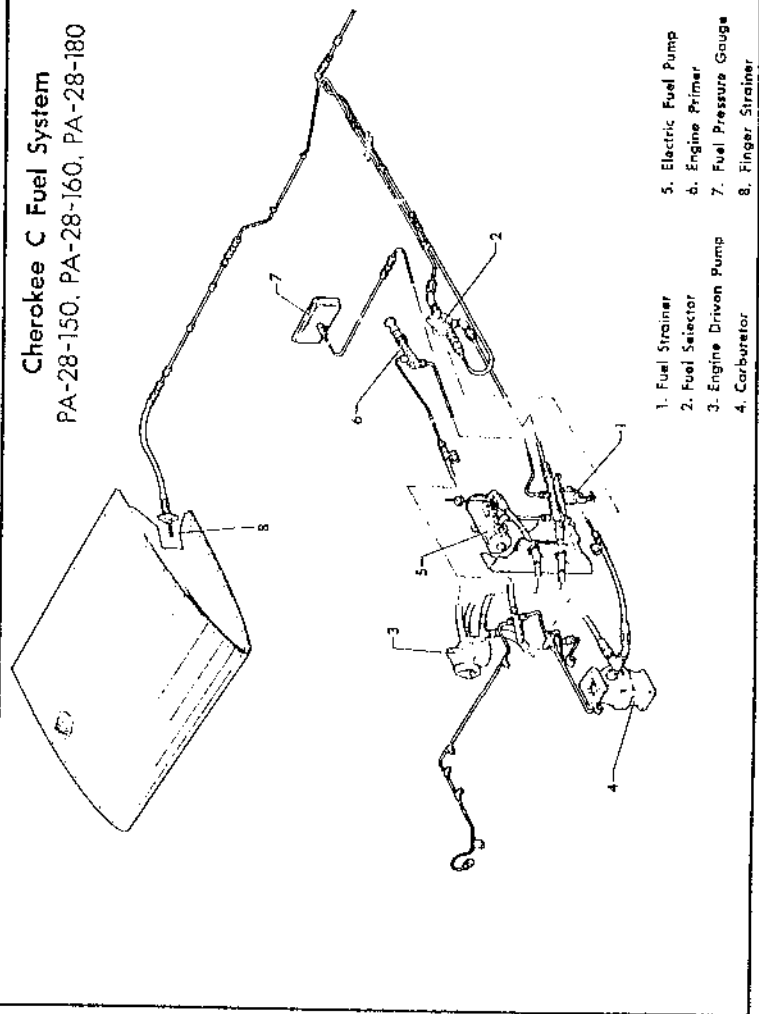

- 1. Fuel Strainer
- 2. Fuel Selector
- 3. Engine Driven Pump
- 4. Carburetor
- 5. Electric Fuel Pump
- 6. Engine Primer
- 7. Fuel Pressure Gauge
- 8. Finger Strainer

When air bubbles cease to flow through the hose, compress the strut fully and again check fluid level. Reinstall the valve core and filler plug, and the main gear torque links, if disconnected.

With fluid in the strut housing at the correct level, attach a strut pump to the air valve and with the airplane on the ground, inflate the oleo strut to the correct height.

In jacking the Cherokee for landing gear or other service, a jack kit (available through Piper Dealers or Distributors) should be used. This kit consists of two hydraulic jacks and a tail stand. At least 250 pounds of ballast should be placed on the base of the tail stand before jacking up the airplane. The hydraulic jacks should be placed under the jack points on the bottom of the wing and the airplane jacked up until the tail skid is at the right height to attach the tail stand. After attaching the tail stand, and adding the ballast, the jacking may be continued until the aircraft is at the height desired.

FUEL REQUIREMENTS

The minimum aviation grade fuel is 80/87 for the PA-28-150 and 91/96 for the PA-28-160 and 180. Since the use of lower grades can cause serious engine damage in a short period of time, the engine warranty is invalidated by the use of lower octanes.

Whenever 80/87 is not available, the lowest lead 100 grade should be used. (See Fuel Grade Comparison Chart, next page.) Refer to the latest issue of Lycoming Service Instruction No. 1070 for additional information.

The continuous use, more than 25% of the operating time, of the higher leaded fuels can result in increased engine deposits, both in the combustion chamber and in the engine oil. It may require increased spark plug maintenance and more frequent oil changes. The frequency of spark plug maintenance and oil drain periods will be governed by the amount of lead per gallon and the type of operation. Operation at full rich mixture requires more frequent maintenance periods; therefore, it is important to use proper approved mixture leaning procedures.

Reference the latest issue of Lycoming Service Letter No. L185 for care, operation and maintenance of the airplane when using the higher leaded fuel.

A summary of the current grades as well as the previous fuel designations are shown in the following chart:

FUEL GRADE COMPARISON CHART

Previous Commercial Fuel Grades (ASTM-D910)			Current Commercial Fuel Grades (ASTM-D910-75)			Current Military Fuel Grades (MIL-G-5572E) Amendment No. 3		
Grade	Color	Max. TEL ml/U.S. gal.	Grade	Color	Max. TEL ml/U.S. gal.	Grade	Color	Max. TEL ml/U.S. gal.
80/87	red	0.5	80	red	0.5	80/87	red	0.5
91/98	blue	2.0	* 100LL	blue	2.0	none	none	none
100/130	green	3.0	100	green	** 3.0	100/130	green	** 3.0
115/145	purple	4.6	none	none	none	115/145	purple	4.6

* - Grade 100LL fuel in some over seas countries is currently colored green and designated as "100L."

** - Commercial fuel grade 100 and grade 100/130 (both of which are colored green) having TEL content of up to 4 ml/U.S. gallon are approved for use in all engines certificated for use with grade 100/130 fuel.

OIL REQUIREMENTS

The oil capacity of the O-320 series engine is 8 quarts, and the minimum safe quantity is 2 quarts. The O-540 holds 12 quarts and the minimum safe quantity is 3 quarts. It is recommended that the oil be changed every 50 hours and sooner under unfavorable operating conditions. Intervals between oil changes can be increased as much as 100% on engines equipped with full flow cartridge type oil filters, provided the element is replaced each 50 hours of operation and the specified octane fuel is used. Should fuel other than the specified octane rating for the power plant be used, refer to the latest issue of Lycoming Service Letter No. L185 and Lycoming Service Instruction No. 1014 for additional information and recommended service procedures. The following grades are recommended for the specified temperatures:

Average Ambient Air Temperature For Starting	Single Viscosity Grade	Multi-Viscosity Grades
Above 60° F	SAE 50	SAE 40 or SAE 50
30° to 90° F	SAE 40	SAE 40
0° to 70° F	SAE 30	SAE 40 or 20W-30
Below 10° F	SAE 20	SAE 20W-30

Either mineral oil or ashless-dispersant oil may be used, but the two types of oil may never be mixed.

CARE OF AIR FILTER

The carburetor air filter must be cleaned at least once every fifty hours. Under extremely adverse conditions of operation it may be necessary to clean the filter daily. Extra filters are inexpensive and a spare should be kept on hand and used as a rapid replacement.

The filter manufacturer recommends that the filter be tapped gently to remove dirt particles. Do not blow out with compressed air.

CARE OF WINDSHIELD AND WINDOWS

A certain amount of care is needed to keep the plexiglas windows clean and unmarred. The following procedure is recommended:

1. Flush with clean water and dislodge excess dirt, mud, etc., with your hand.
2. Wash with mild soap and water. Use a soft cloth or sponge, do not rub.
3. Remove oil, grease or sealing compounds with a soft cloth and kerosene.
4. After cleaning, apply a thin coat of hard polishing wax. Rub lightly with a soft cloth.
5. A severe scratch or mar may be removed by using jeweler's rouge to rub out the scratch, smoothing, and then applying wax.

SERIAL NUMBER PLATE

The serial number plate is located near the stabilator on the left side of the airplane. Refer to this number for service or warranty matters.

**CHEROKEE ELECTRICAL
SYSTEM SCHEMATIC
ALTERNATOR**

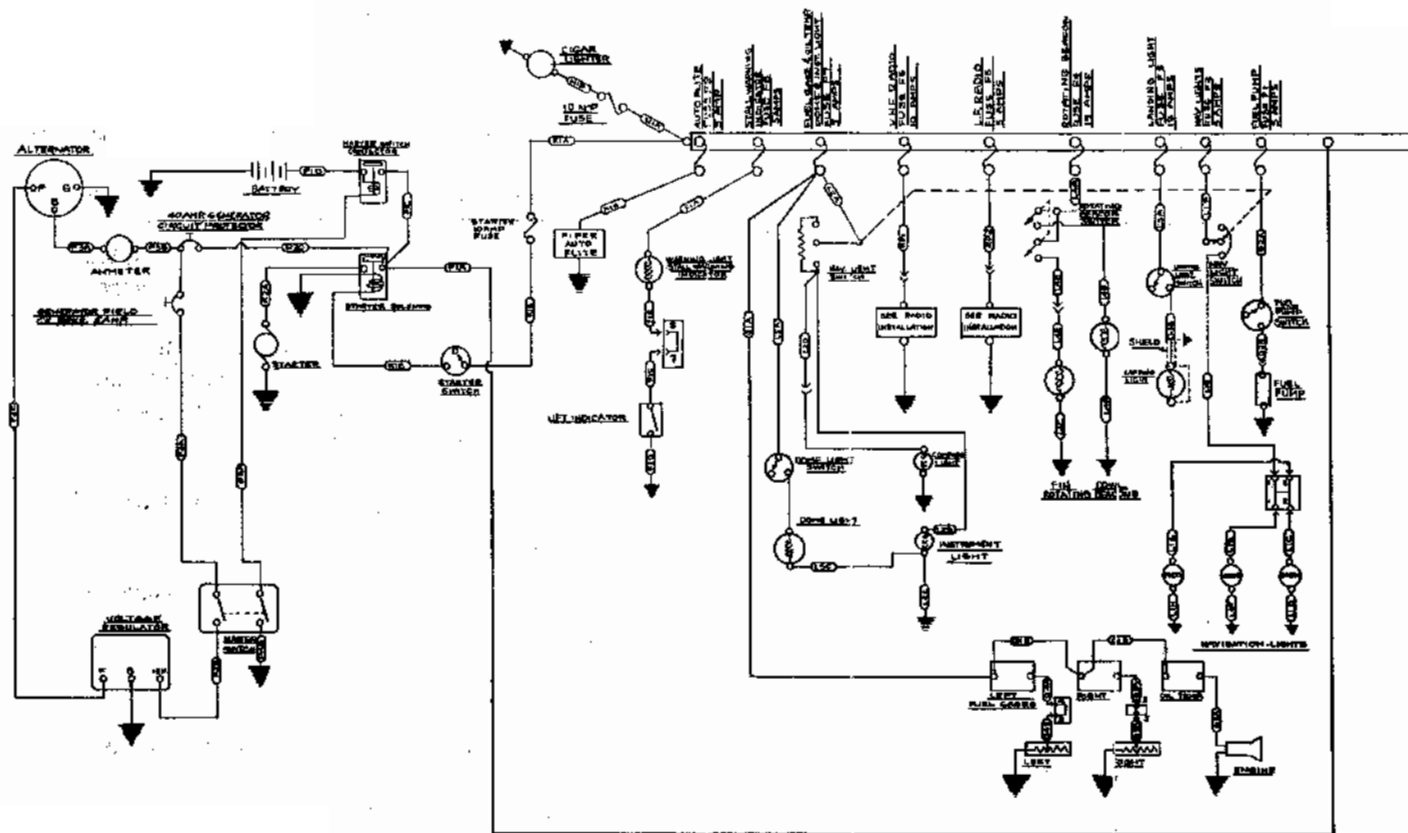

LEVELING AND RIGGING

Leveling the Cherokee for purposes of weighing or rigging is accomplished as follows:

1. Partially withdraw two machine screws located immediately below the left front side window. These screws are leveling points and the airplane is longitudinally level when a level placed on the heads of these screws indicates level.

2. To put the airplane in a longitudinally level position on scales, first block the main gear oleos in the fully extended position, then deflate the nose wheel tire until the proper attitude is obtained. For rigging only, the airplane may be placed on jacks for leveling.

3. To level the airplane laterally, place a level across the baggage compartment floor along the rear bulkhead.

Rigging: Although the fixed flight surfaces on the Cherokee cannot be adjusted for rigging purposes, it may be necessary upon occasion to check the position of these surfaces. The movable surfaces all have adjustable stops, as well as adjustable turnbuckles on the cables or push-pull tubes, so that their range of travel can be altered. The positions and angular travels of the various surfaces are as follows:

1. Wings: 7° dihedral, 2° washout.
2. Stabilator Travel: 18° up, 2° down, tolerance $\pm 1^\circ$.
3. Fin should be vertical, and in line with center of fuselage.
4. Ailerons Travel: 30° up, 15° down, tolerance $\pm 2^\circ$.
5. Flaps travel: 10°, 25°, 40°, tolerance $\pm 2^\circ$.
6. Rudder Travel: 27° right and left, tolerance $\pm 2^\circ$.
7. Stabilator Tab Travel: 3° up, 12° down, tolerance $\pm 1^\circ$.

Cable tensions for the various controls are as follows:

Rudder: 40 ± 5 #	Stabilator Trim: 5 ± 1 #
Ailerons: 40 ± 5 #	Flap: 10 ± 2 #
Stabilator: 40 ± 5 #	

For extreme cases of wing heaviness, either of the flaps may be adjusted up or down from the zero position as desired.

LUBRICATION CHART
FOR
PIPER CHEROKEE PA-28

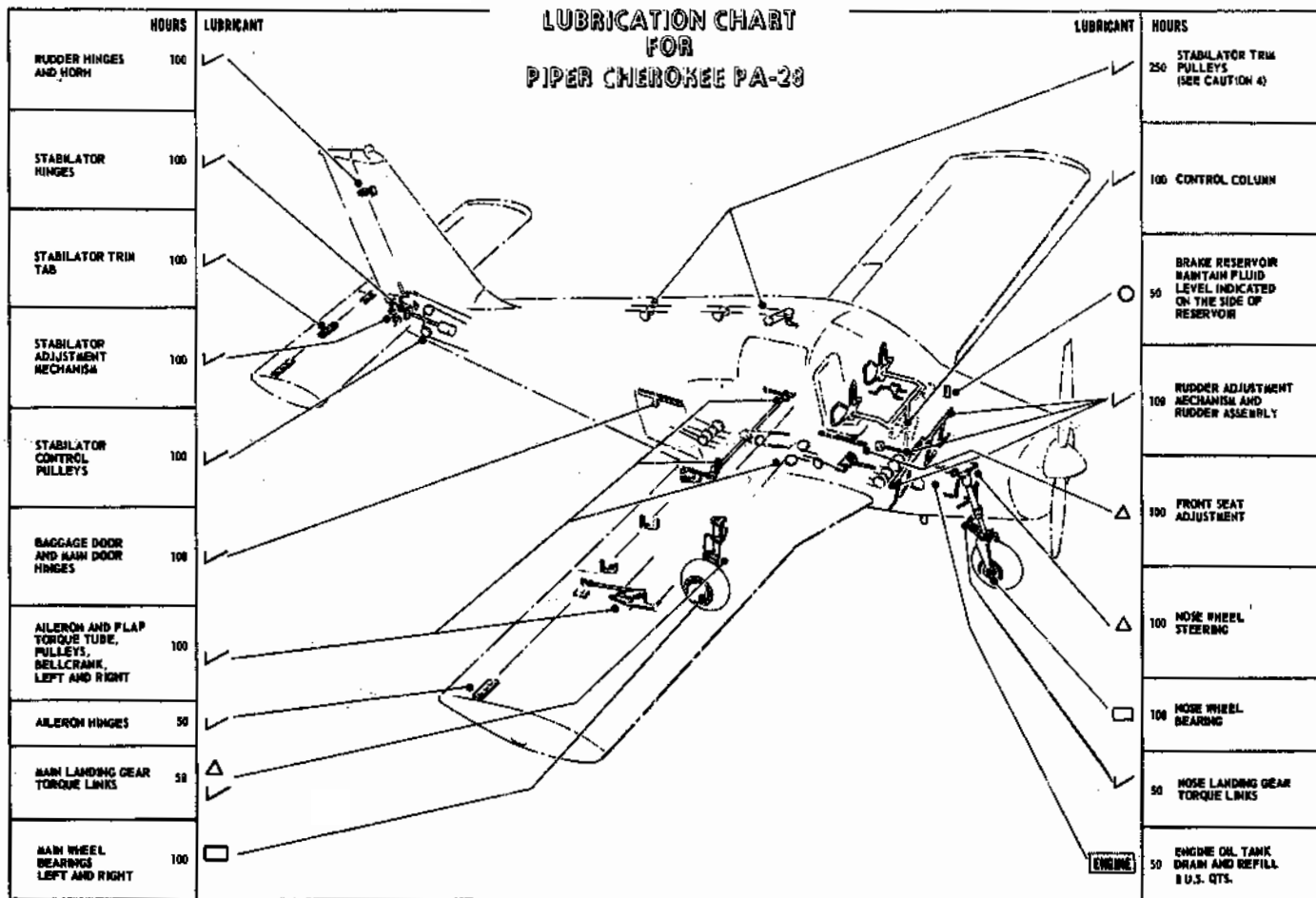

NOTES

- FUEL SYSTEM - THE FOLLOWING POINTS REQUIRE REGULAR SERVICING - FUEL PUMP STRAINER, CARBURETOR SCREEN, FILTER BOWL, QUICK DRAIN UNIT.
- LANDING GEAR STRUTS - FOLLOW INSTRUCTION PLACARD ON OLEO STRUT.
- MISCELLANEOUS - DURING ROUTINE MAINTENANCE CHECKS, APPLY LUBRICATION TO MISCELLANEOUS LINKAGES.
- BATTERY - CHECK BATTERY FLUID LEVEL & BATTERY CONDITION EVERY 25 HOURS.

LEGEND

- ✓ MIL-L-7810 OIL - GENERAL PURPOSE LOW TEMP. LUBRICATION.
- △ NL-G-23827 GREASE - LUBRICATION GENERAL PURPOSE AIRCRAFT.
- NL-L-3545 GREASE - LUBRICATION HIGH TEMP.
- NL-H-5606 HYDRAULIC FLUID (RED). SAE 50 ABOVE 60° F AIR TEMP. * SAE 40 30° F TO 50° F AIR TEMP. * SAE 30 0° F TO 70° F AIR TEMP. * SAE 20 BELOW 10° F AIR TEMP. *

ENGINE

CAUTIONS

- DO NOT USE A HYDRAULIC FLUID WITH A CASTOR OIL OR ESTER BASE.
- DO NOT OVER-LUBRICATE PEDESTAL CONTROLS.
- DO NOT APPLY LUBRICANT TO RUBBER PARTS.
- UNDER NO CIRCUMSTANCES SHOULD THE TRIM CABLES FROM THE COCKPIT TO THE REAR OF THE FUSELAGE BE LUBRICATED - AS THIS MAY CAUSE SLIPPAGE.
- REMOVE ALL EXCESS GREASE FROM GREASE FITTINGS.
- OIL ALERON HINGES EVERY FIFTY HOURS.
- NON-DETERGENT - SEE LYCOMING SERVICE INSTRUCTIONS NO. 1014 FOR USE OF DETERGENT OIL.

INDEX

SECTION I	Page
Specification Features	1
Power Plant	1
Performance	1
Weights	2
Fuel and Oil	3
Baggage	3
Dimensions	3
Landing Gear	3
 SECTION II	
Design Information	5
Engine and Propeller	5
Structures	5
Landing Gear	6
Control Systems	7
Fuel System	7
Electrical System	8
Heating and Ventilating System	9
Cabin Features	9
 SECTION III	
Operating Instructions	13
Preflight	13
Starting	14
Warm-up	15
Ground Check	16
Takeoff	16
Climb	17
Stalls	17
Cruising	17
Approach and Landing	18
Ground Handling and Mooring	19
Weight and Balance	20

INDEX (cont)

SECTION IV	Page
Performance Charts:	21
Take-off Distance vs Density Altitude.....	21
Rate of Climb vs Density Altitude.....	22
True Airspeed and RPM vs Density Altitude, PA-28-150-160	23
Range vs Density Altitude, PA-28-150-160.....	24
True Airspeed and RPM vs Density Altitude, PA-28-180.....	25
Range vs Density Altitude, PA-28-180	26
Landing Distance vs Density Altitude.....	26a
Altitude Conversion Chart.....	26b
 SECTION V	
General Maintenance:.....	27
Tire Inflation	27
Battery Service.....	27
Brake Service	27
Landing Gear Service	28
Fuel Requirements	30
Oil Requirements.....	31
Care of Air Filter	32
Care of Windshield and Windows	32
Serial Number Plate	32
Leveling and Rigging	34